

RoHS



## MLVS0201 Series Engineering Specification

### 1. Scope

- (1) SMD type zinc oxide based ceramic chip
- (2) Lead free plating termination provided good solderability characteristic
- (3) Insulator over coat keeps excellent low and stable leakage current
- (4) Quick response time (<1ns)
- (5) Low clamping voltage
- (6) High transient current capability
- (7) Meet IEC 61000-4-2 standard
- (8) Compact size for ELA 0201

### Applications

**Applications** for Mother Board and Notebook, Cellular Phone, PDA, handheld device, DSC, DV, Scanner, and Set-Top Box etc.

**Suitable** for Push-Button, Power Line and Low Frequency single line over voltage protect.

### 2. Explanation of Part Number

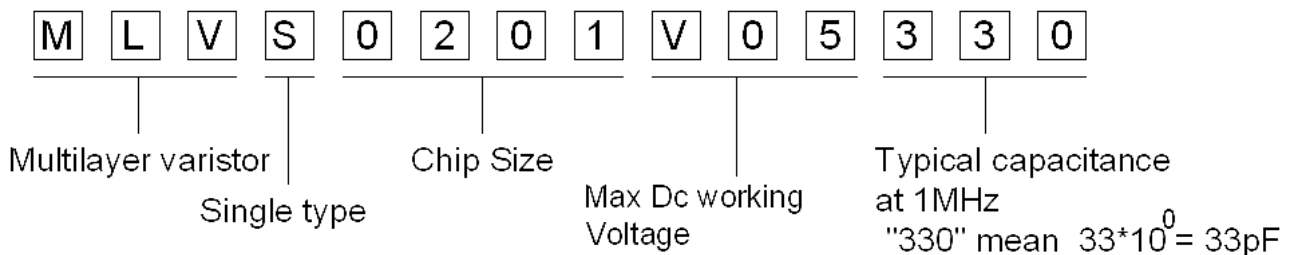

### 3. Construction & Dimension

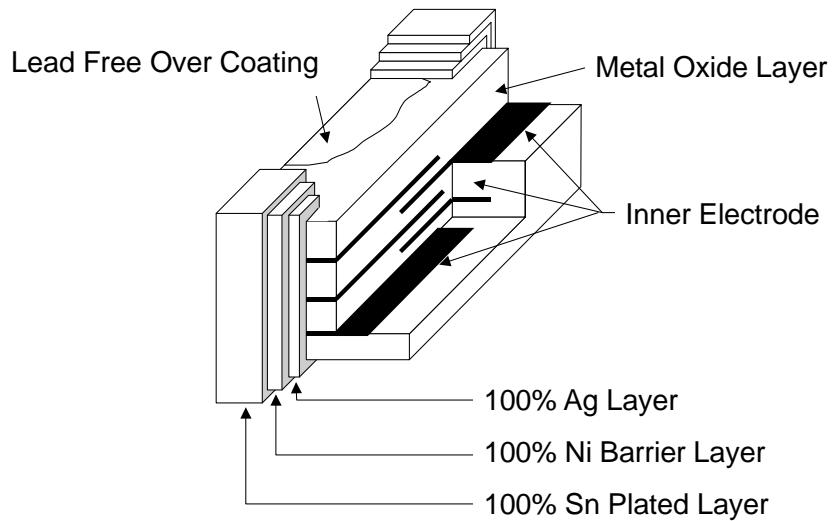
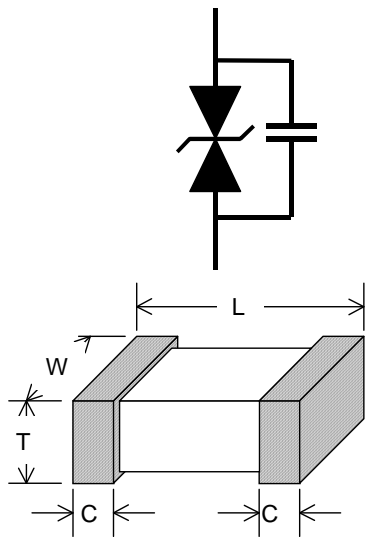

Unit: mm	0201
L	0.60±0.05
W	0.30±0.05
T	0.30±0.05
C	0.20±0.10

### 4. Part ratings

#### 4.1. Rating(25±5°C)

Symbol	Working voltage		Varistor voltage		Clamping Voltage V <sub>c</sub>	Capacitance C <sub>p</sub>	Peak current i <sub>max</sub>	Transient energy W <sub>max</sub>
	V <sub>RMS</sub>	V <sub>DC</sub>	V <sub>V</sub>	ΔV <sub>V</sub>				
Units	Volts	Volts (Max.)	Volts	%	Volts (Max.)	pF (Typical)	Amps (Max.)	Joules (Max.)
Test Condition		< 10 μA	1mA DC		1 A 8/20μs	1MHz	8/20μs	10/1000μs
MLVS0201V05330	4	5.5	11	±3	28	33	-	-

V<sub>RMS</sub> – Maximum AC operating voltage the varistor can maintain and not exceed 10μA leakage current

V<sub>DC</sub> – Maximum DC operating voltage the varistor can maintain and not exceed 10μA leakage current

V<sub>V</sub> –Voltage across the device measured at 1mA DC current.

Equivalent to  $V_b$ , "Breakdown Voltage".

$V_c$  – Maximum peak voltage across the varistor measured at 8/20us waveform and 1A pulse current

$C_p$  – Device capacitance measured with zero volt bias 1Vrms at 1MHz.  
Capacitance Tolerance: M=±20% , K=±10%.

$i_{max}$  – Maximum peak current which may be applied with 8/20us waveform without device failure

$W_{max}$  – Maximum energy that may be dissipated with the 10/1000us waveform without device failure

## 5. General electrical specifications

### 5.1. General technical data

Operating temperature	-40°C ~ +85°C
Storage temperature (on board)	-40°C ~ +85°C
Response time	<1 ns
Solderability	245±5°C, 3±1sec.
Solder leach resistance	260±5°C, 10±1sec.

### 5.2 Environmental Specifications

Characteristics	Specifications	Test condition
Bias humidity	$\Delta V_V / V_V \leq \pm 10\%$	90%RH, 40°C, Working voltage, 1000 hours
Thermal shock	$\Delta V_V / V_V \leq \pm 10\%$	-40°C to 85°C, 30 min. Cycle, 5 cycles
Full load voltage	$\Delta V_V / V_V \leq \pm 10\%$	Working voltage, 85°C, 1000 hours

### 5.3. Storage Condition with package

Storage Time: 12 months max

Storage Temperature : 5 to 40°C

Relative Humidity: to 65 %

## 6. Taping Package and Label Marking

### 6.1. Packaging method

Products shall be heat-sealed in the chip pocket; spacing pitch 4-mm of plastic carrier tape with cover tape, and the carrier tape shall be reeled to the reel.

### 6.2. Carrier tape dimensions

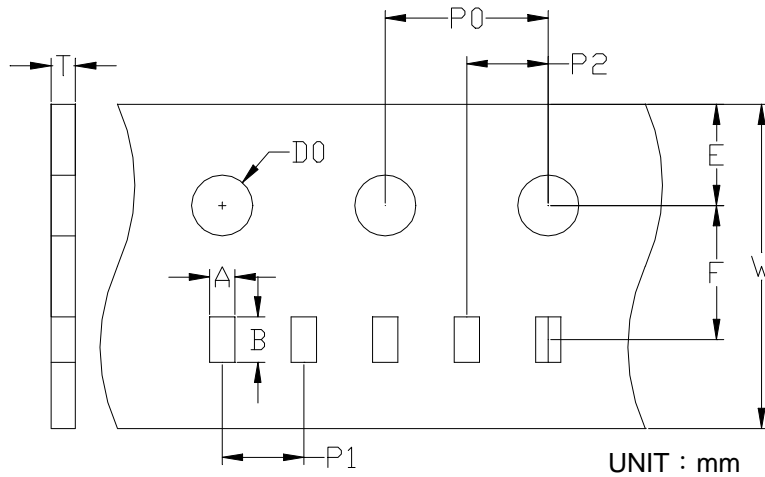

Type	A	B	W	E	F	P0	P1	P2	D0	T
0201	0.36 ±0.02	0.70 ±0.02	8.0 ±0.1	1.75 ±0.05	3.5 ±0.05	4.0 ±0.1	2.0 ±0.05	2.0 ±0.05	1.55 ±0.05	0.42 ±0.02

### 6.3. Taping reel dimensions

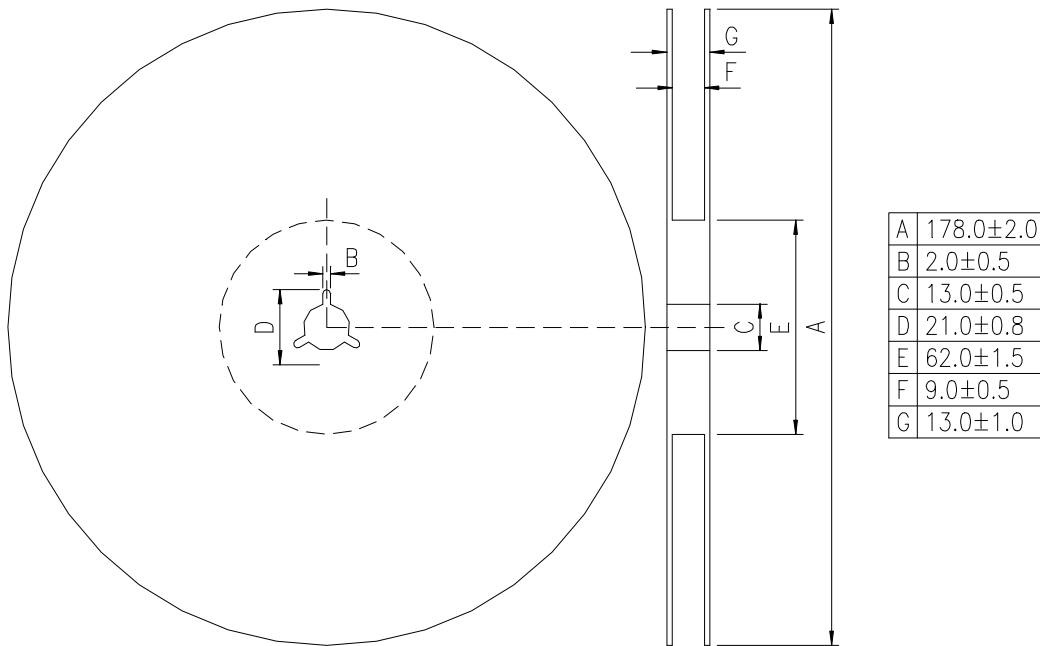

### 6.4 Taping specifications

There shall be the portion having no product in both the head and the end of taping, and there shall be the cover tape in the head of taping.

### 6.5. Label Marking

The label specified as follows shall be put on the side of reel.

(1) Part No.

(2) Quantity

(3) Lot No.

\*Part No. And Quantity shall be marked on outer packaging.

**6.6. Quantity of products in the taping package**

(1) Standard quantity : 15,000pcs/Reel for MLVS0201Series

(2) Shipping quantity is a multiple of standard quantity.

**7. Precautions for Handling**

**7.1. Solder cream in reflow soldering**

Refer to the recommendable land pattern as printing mask pattern for solder cream.

0201

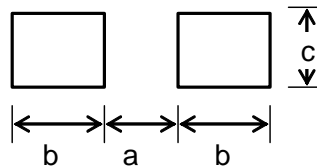

Dimensions in mm

Type	a	b	c
0201	0.4±0.1	0.5±0.05	0.5±0.1

**7.2. Precaution for handling of substrate**

Do not exceed to bend the board after soldering this product extremely.

(Reference examples)

- Mounting place must be as far as possible from the position, which is close to the break line of board, or on the line of large holes of board.

- Do not bend extremely the board, in mounting another components.  
If necessary, use back-up pin (support pin) to prevent from bending extremely.
- Do not break the board by hand. We recommend using the machine or the jig to break it.

**7.3. Precaution for soldering**

Note that rapid heating, rapid cooling or local heating will easily damage this product.

Do not give heat shock over 100°C in the process of soldering. We recommend taking preheating and gradual cooling.

**7.4. Recommendable reflow soldering**

Profile Feature	Pb-Free Assembly
Average Ramp-Up Rate (T <sub>smax</sub> to T <sub>p</sub> )	3° C/second max.
<b>Preheat</b> – Temperature Min (T <sub>smin</sub> ) – Temperature Max (T <sub>smax</sub> ) – Time (t <sub>smin</sub> to t <sub>smax</sub> )	150 °C 200 °C 60-180 seconds
Time maintained above: – Temperature (T <sub>L</sub> ) – Time (t <sub>L</sub> )	217 °C 60-150 seconds
Peak/Classification Temperature (T <sub>p</sub> )	260 °C
Time within 5 °C of actual Peak Temperature (t <sub>p</sub> )	20-40 seconds
Ramp-Down Rate	6 °C/second max.
Time 25 °C to Peak Temperature	8 minutes max.

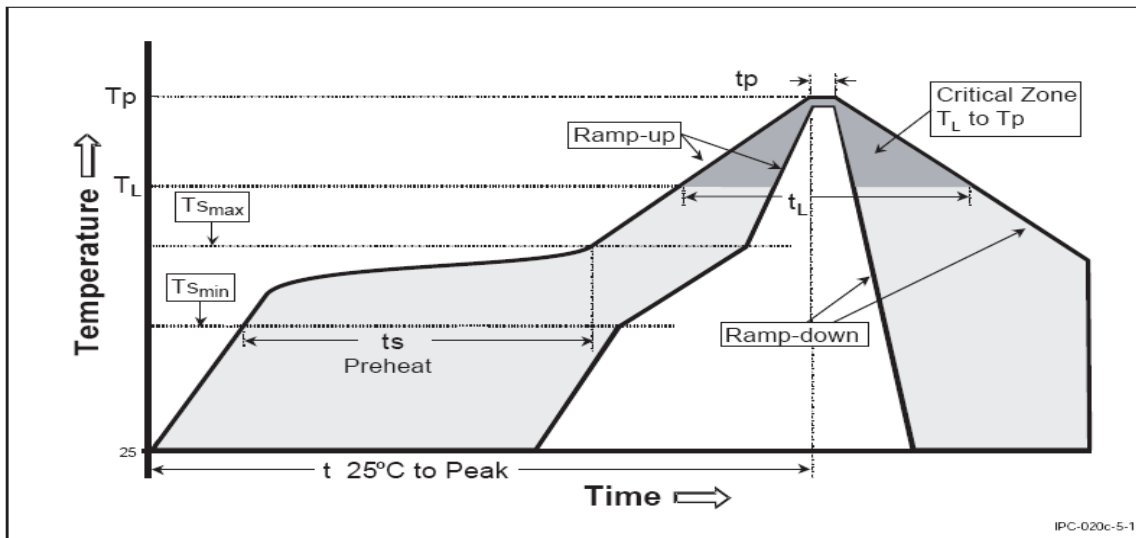

\*Areference: J-STD-020C

### 7.5. Soldering gun procedure

Note the follows, in case of using soldering gun for replacement.

- (1) The tip temperature must be less than 280°C for the period within 3 seconds by using soldering gun less than 30 W.
- (2) The soldering gun tip shall not touch this product directly.

### 7.6. Soldering volume

Note that excess of soldering volume will easily get crack the body of this product.